

sunways

AU

User Manual

Grid-connected Inverter

STS 3~6KTL

sunways

CONTENTS

1 Preface	5
1.1 Overview	5
1.2 Target Groups	5
2 Safety Instructions	6
2.1 Safety Notes	6
2.2 Statement	6
2.3 Important Safety Matters	7
2.4 Symbols Explanation	8
3 Product Description	11
3.1 Basic Features	11
3.2 Physical Layout	12
3.3 Display Interface	14
3.4 Packing List	15
4 Installation	18
4.1 Location	18
4.2 Mounting	20
4.3 External ground connection	23
4.4 Electrical Connection	24
4.5 Monitoring Device Installation	31
4.6 CT/RS485/DRED Connection	32
5 Start and Stop	36
5.1 Start the Inverter	36
5.2 Stop the Inverter	36
6 General Operation	37
6.1 Display Operation	37
6.2 Country Code (Safety Code) Setting	38
6.3 Auto-Test	39
6.4 Power Quality Response Modes	39
6.5 Online Monitoring APP	40
7 Troubleshooting	41
7.1 Error Message	41
7.2 Maintenance	44
8 Technical Parameters	45

Attention

The products, services or features purchased are subject to the commercial contracts and terms of Sunways technologies Co., Ltd. All or part of the products, services or features described in this document may not be within purchased. Unless otherwise agreed in the contract, the Company shall not make any express or implied declaration or guarantee of the contents of this document.

Due to product version upgrades or other reasons, the contents of this document will be updated periodically. Unless otherwise agreed, this document serves only as a guide to use, and all statements, information and recommendations in this document do not constitute any express or implied guarantee.

» 1 Preface

※ 1.1 Overview

This manual is an integral part of Sunways STS 3-6kW series single-phase inverters (hereinafter referred to as the inverter). It mainly introduces the assembly, installation, electrical connection, maintenance and troubleshooting of the products. Before installing and using the inverter, please read this manual carefully, understand the safety information and be familiar with the functions and characteristics of the inverter.

※ 1.2 Target Groups

This manual is applicable to the electrical installers with professional qualifications and end-users. If there are any problems in the installation process, please call Sunways service telephone at +86 400-9922-958 or email Sunways at service@sunways-tech.com for consultation.

» 2 Safety Instructions

※ 2.1 Safety Notes

- ① Before installation, please read this manual carefully and follow the instructions in this manual strictly.
- ② Installers need to undergo professional training or obtain electrical related professional qualification certificates.
- ③ When installing, do not open the front cover of the inverter. Apart from performing work at the wiring terminal (as instructed in this manual), touching or changing components without authorization may cause injury to people, damage to inverters and annulment of the warranty.
- ④ All electrical installations must conform to local electrical safety standards.
- ⑤ If the inverter needs maintenance, please contact the local designated personnel for system installation and maintenance.
- ⑥ To use this grid-connected inverter for power generation needs the permission of the local power supply authority.
- ⑦ The temperature of some parts of the inverter may exceed 60° C during operation. To avoid being burnt do not touch the inverter during operation. Let it cool before touching it.
- ⑧ When exposed to sunlight, the PV array generates dangerous high DC voltage. Please operate according to our instructions, or it will result in danger to life.

※ 2.2 Statement

Sunways Technologies Co.,Ltd. has the right not to undertake quality assurance in any of the following circumstances:



- ① Damages caused by improper transportation.
- ② Damages caused by incorrect storage, installation or use.
- ③ Damages caused by installation and use of equipment by non-professionals or un-

trained personnel.

- ④ Damages caused by failure to comply with the instructions and safety warnings in this document.
- ⑤ Damages of running in an environment that does not meet the requirements stated in this document.
- ⑥ Damages caused by operation beyond the parameters specified in applicable technical specifications.
- ⑦ Damages caused by unauthorized disassembly, alteration of products or modification of software codes.
- ⑧ Damages caused by abnormal natural environment (force majeure, such as lightning, earthquake, fire, storm, etc.).
- ⑨ Any damages caused by the process of installation and operation which don't follow the local standards and regulations.
- ⑩ Products beyond the warranty period.

※ 2.3 Important Safety Matters

Table below shows the symbols that may appear in this document and their definition:

 Danger	Dangerous situation, if not avoided, it could result in death or serious personal injury.
 Warning	Potentially dangerous situation, if not avoided, may result in death or serious personal injury.
 Caution	Potentially dangerous situation, if not avoided, may result in moderate or minor personal injury.

	The safety warning information about equipment or environment, to prevent equipment damage, data loss, equipment performance degradation or other unpredictable results.
Attention	
	Symbol highlights important information, best practices and tips, etc.
Note	

※ 2.4 Symbols Explanation

This chapter mainly elaborates the symbols displayed on the inverter, nameplate and packing box.





▼ 2.4.1 Symbols on the Inverter

	Inverter status indicator.
	Inverter running indicator.
	Grounding symbol, the inverter casing needs to be properly grounded.

▼ 2.4.2 Symbol on the Inverter nameplate

	The inverter cannot be disposed of with household waste.
	Please read the instructions carefully before installation.
	Do not touch any internal parts of the inverter until 5 min after being disconnected from the mains and PV input.
	CE mark, the inverter complies with the requirements of the applicable CE guidelines.
	TUV certification.
	Danger. Risk of electric shock!
	The surface is hot during operation and no touch is allowed.
	Electric shock hazard, live parts, risk of electric shock, do not touch.

▼ 2.4.3 Symbol on the Packing box

	<p>Handle with care.</p>
	<p>This side up.</p>
	<p>Keep dry.</p>
	<p>Stacked layers.</p>

» 3 Product Description

※ 3.1 Basic Features

▼ 3.1.1 Function

The Sunways STS 3-6kW series inverter is a single-phase grid-connected PV inverter which used to efficiently convert the DC power generated by the PV string into AC power and feed it into the grid.

▼ 3.1.2 Models

The STS 3-6kW series inverter includes 6 models which are listed below:

STS-3KTL, STS-3.6KTL, STS-4.2KTL, STS-4.6KTL, STS-5KTL, STS-6KTL

STS-3KTL-P, STS-3.6KTL-P, STS-4.2KTL-P, STS-4.6KTL-P, STS-5KTL-P, STS-6KTL-P

▼ 3.1.3 Applicable grid type

The applicable grid types for the Sunways STS 3-6kW series are TN-S, TN-C, TN-C-S and TT. When applied to the TT grid, the voltage of N to PE should be less than 30V. For more details please see Figure 3-1:

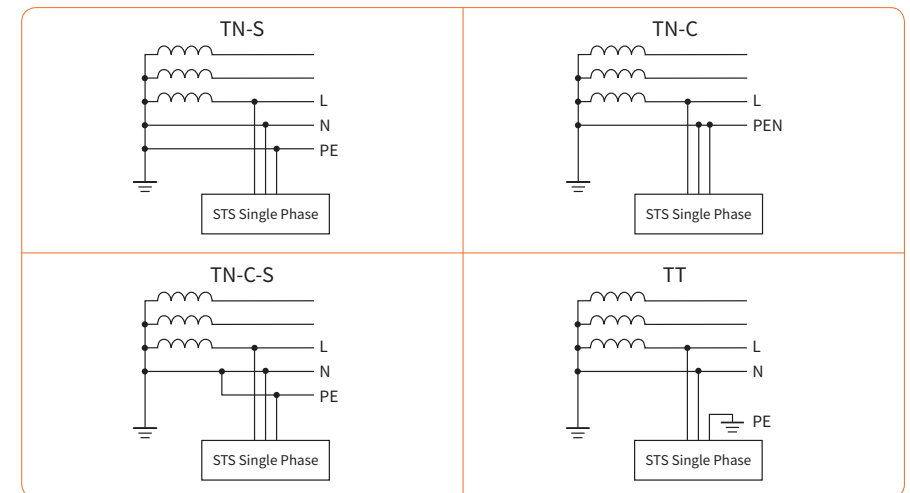

Figure 3-1 Applicable grid types

▼ 3.1.4 Storage conditions

- ① Inverter must be stored in its original packaging.
- ② The storage temperature and humidity should be in the range of -30°C and +60°C, and less than 90%, respectively.
- ③ If a batch of inverters needs to be stored, the height of each pile should be no more than 6 levels.

※ 3.2 Physical Layout

▼ 3.2.1 Inverter front view

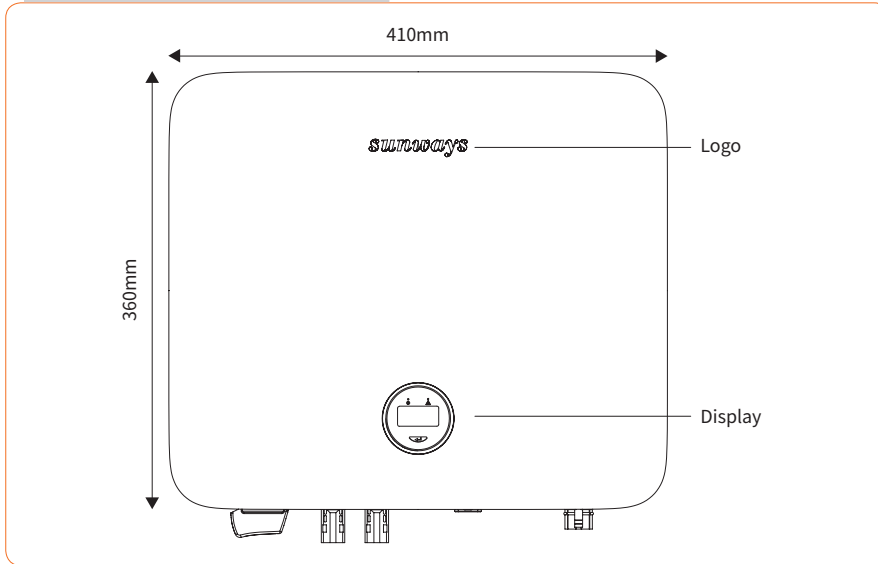

Figure 3-2 Front view

▼ 3.2.2 Inverter side view

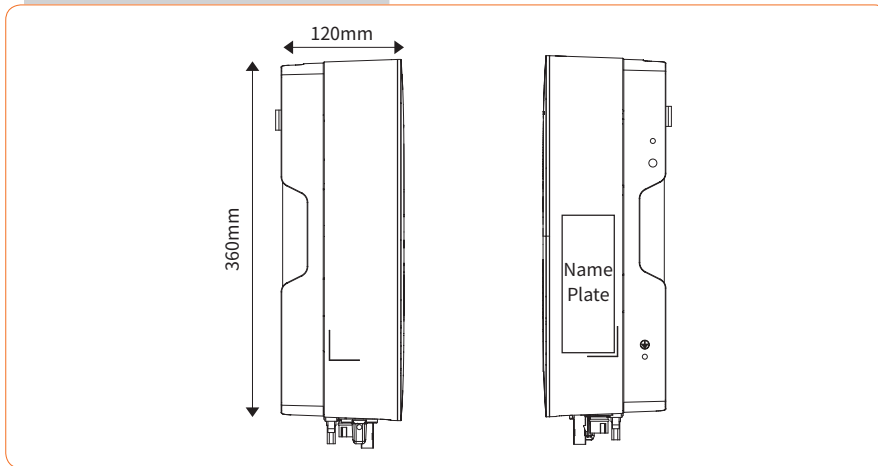

Figure 3-3 Side view

▼ 3.2.3 Inverter Bottom View

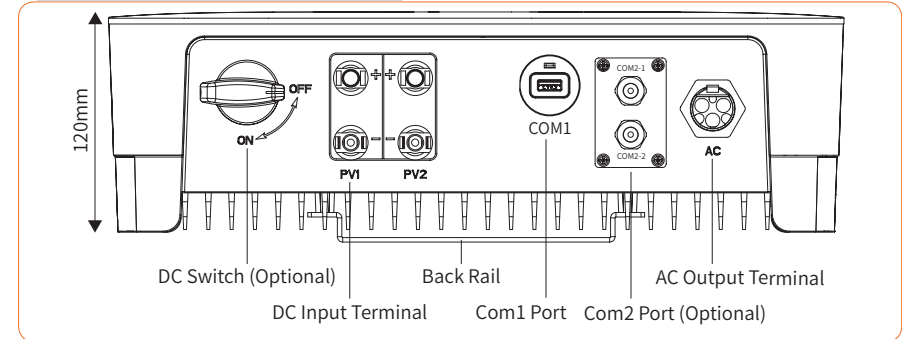

Figure 3-4 Bottom view

Wiring terminals are at the bottom of the inverter, as shown in the table below.

Item	Terminal	Note
1	DC Input terminal	PV connector
2	COM 1 Port	WiFi/LAN/GPRS/4G device connector
3	COM 2 Port	CT/RS485/DRED connector
4	AC Output Terminal	Used for AC output cable connection

▼ 3.2.4 Inverter back view

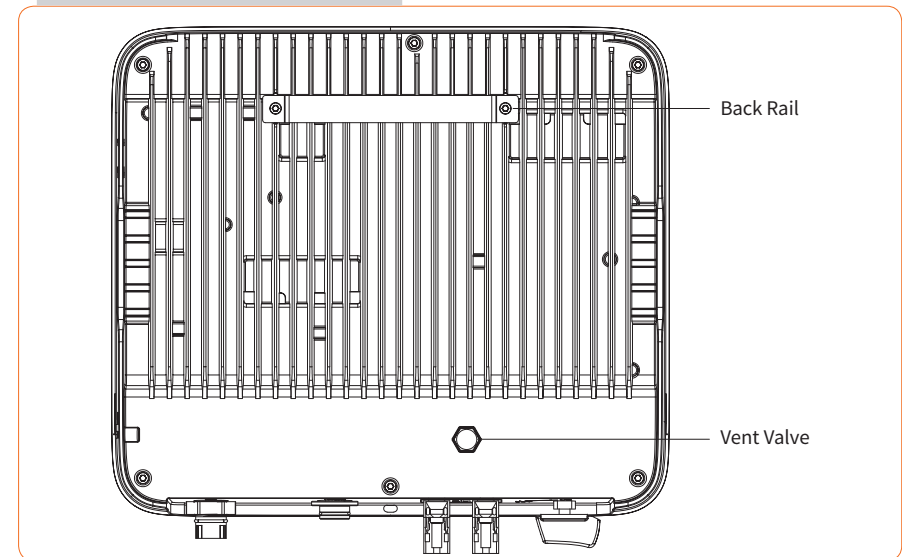

Figure 3-5 Inverter back view

※ 3.3 Display Interface



Figure 3-6 Display interface

Item	Indicator	Status	Description
1	Power Indicator	Off	No input voltage detected or input voltage is too low.
		Slow flashing	Inverter powered on, waiting for the grid connection.
		Quick flashing	Inverter detected grid power and entered self-test status.
		On	Normal, grid-connected and power generated.
2	Alarm Indicator	On	An alarm or faults detected, specific fault information can be viewed from the display.
		Off	The inverter is running normally.
		Slow flashing	The monitoring device is not connected to the router or is not connected to internet.
		Quick flashing	The monitoring device is connected to the router or connected to internet but not connected to the server.

Item	Indicator	Status	Description
3	OLED Display	On	Display the inverter operating information.
		Off	If the button pressed without any response, the screen is faulty or not well connected.
4	Button	Physical button	Switch OLED display information and set parameters by short press and long press.

※ 3.4 Packing List

The package of the inverter includes the following accessories. Please check whether the accessories in the packing box are complete when receiving the goods. See Figure 3-7 for the packing list.

▼ Inverter×1

▼ Wall Bracket×1

▼ Expansion Bolt×4

▼ 3Pin Terminal×1 ①

▼ PV Terminal×2

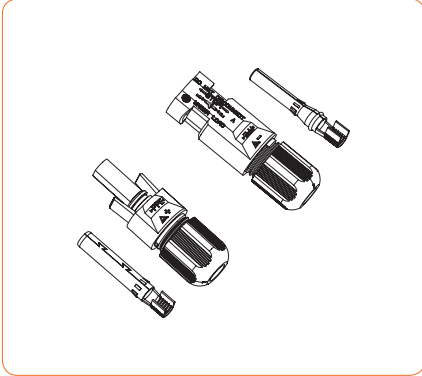

▼ Monitoring Device×1(Optional)

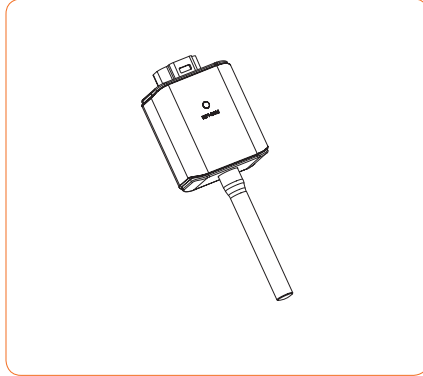

▼ AC Terminal×1^③

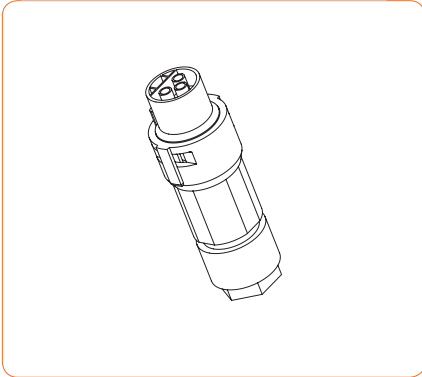

▼ Ground Terminal×1

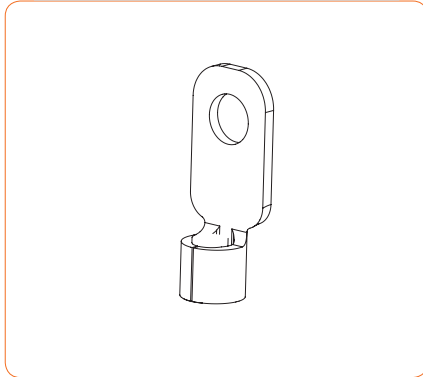

▼ 6Pin Terminal×1^②

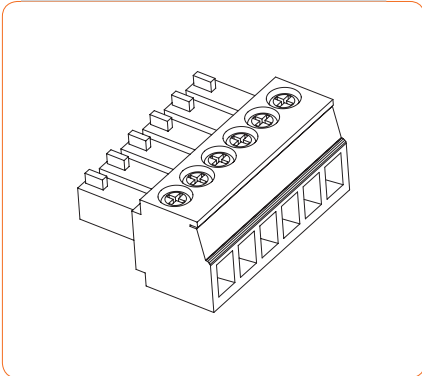

▼ User Guide

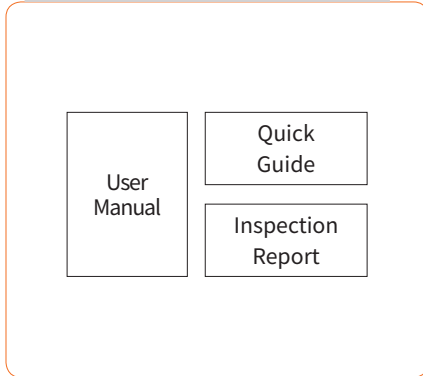

Note

- ① Export limitation & control version 2pcs; RS485 and DRED version 1 pcs (This connector already re-installed inside the inverter).
- ② DRED version only (This connector already pre-installed inside the inverter).
- ③ The AC terminals of STS-3-6KTL and STS-7-11KTL are similar but not exactly same, do not mix them. Sunways has the right to refuse all damages caused by the mixed-use of terminals.

Figure 3-7 Packing list

» 4 Installation

※ 4.1 Location

The Sunways STS 3-6kW series inverters designed with IP65 protection enclosure for indoor and outdoor installations. When selecting an inverter installation location, the following factors should be considered:

- ① The wall on which the inverters mounted must be able to withstand the weight of the inverter.
- ② The inverter needs to be installed in a well-ventilated environment.
- ③ Do not expose the inverter directly to strong sunlight to prevent excessive temperature operation. The inverter should be installed in a place with shelter to prevent direct exposure to sunlight and rain.
- ④ Install the inverter at eye level for easy inspection of screen data and further maintenance.
- ⑤ The ambient temperature of the inverter installation location should be between -30°C and 60°C .
- ⑥ The surface temperature of the inverter may reach up to 75°C . To avoid risk of burns, do not touch the inverter while it's operating and inverter must be installed out of reaching of children.

▼ 4.1.1 Installation location

Recommended installation location of the inverter, as shown in Figure 4-1:

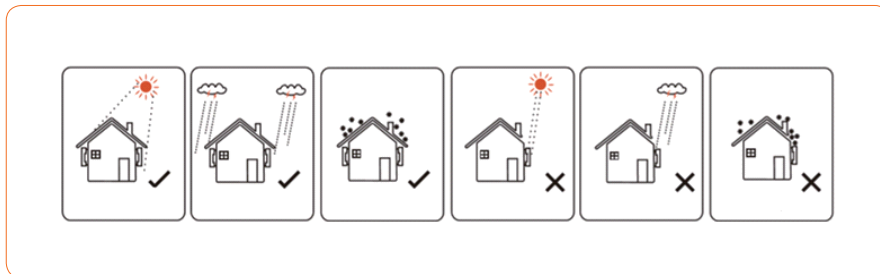

Figure 4-1 Recommended installation location



Warning

Do not put flammable and explosive articles around the inverter.

▼ 4.1.2 Installation Spacing

The requirements for inverter installation spacing are shown in Figure 4-2:

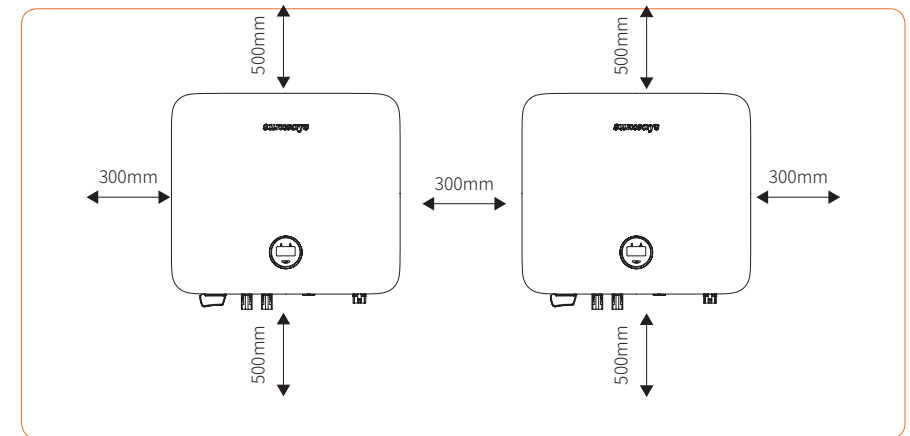

Figure 4-2 Recommended installation spacing

▼ 4.1.3 Installation Angle

The installation angle of the inverter is recommended as shown in Figure 4-3:

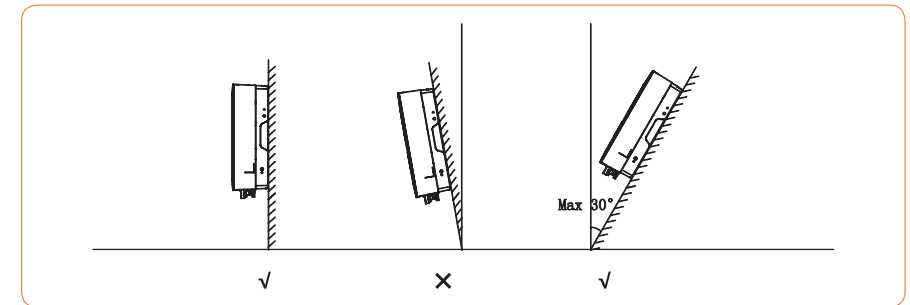

Figure 4-3 Recommended installation angle

※ 4.2 Mounting

▼ 4.2.1 Wall bracket installation

Dimensions of wall bracket, see Figure 4-4:

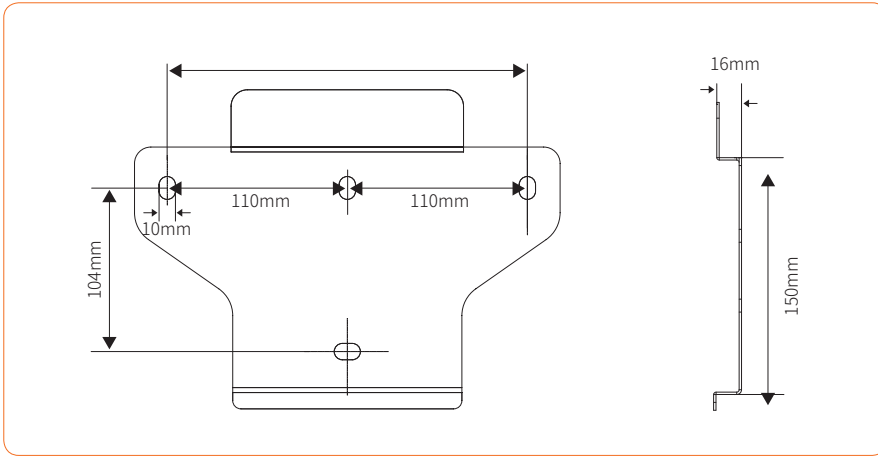

Figure 4-4 Dimensions of wall bracket

① Use the wall bracket as the template to mark the position of 4 holes on the wall. See Figure 4-5 for details:

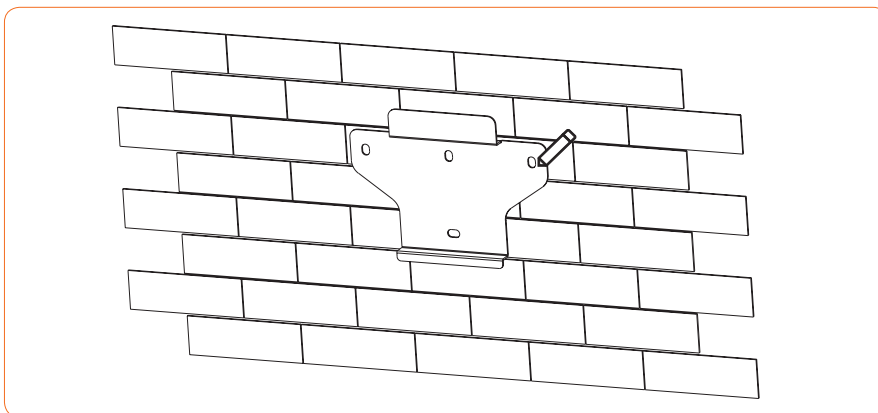

Figure 4-5 Marking hole position using installation bracket

② Bracket assembly

Prepare the two M5 screws and Z-shaped plate in the accessory bag, then fix the Z-shaped plate to the mounting bracket.

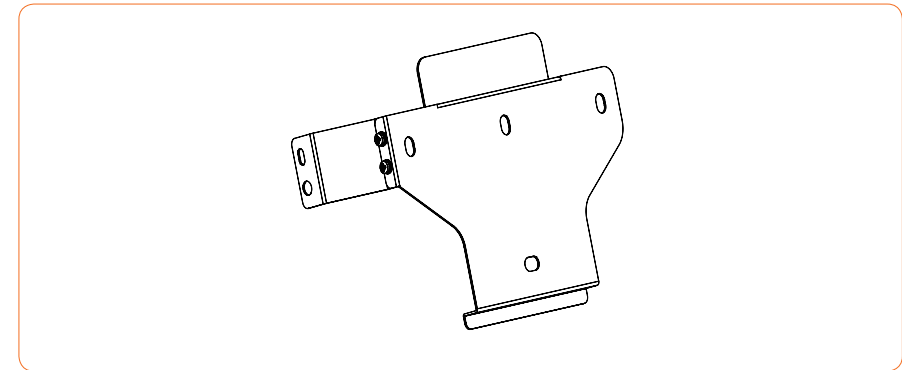

Figure 4-6 Bracket assembly

③ Use an electrical driller with 10mm diameter bit to drill 4 holes in the wall with 80mm depth.



Warning

Before drilling, make sure to avoid any buried water tube and electric wires in the wall.

④ Insert the expansion tubes into the holes and tighten them, then fix the bracket onto the wall with expansion screws by using a cross screwdriver, as shown in Figure 4-7:

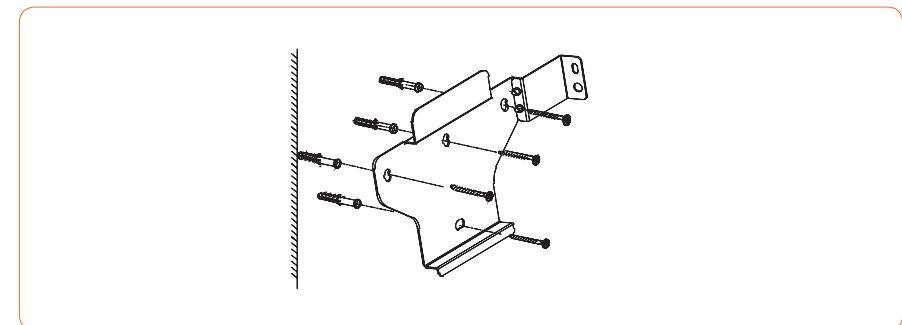

Figure 4-7 Fixing the wall bracket

▼ 4.2.2 Mounting the inverter

Lift the inverter, hang the back rail on the fixed wall bracket carefully. Screws the inverter to the Z-shaped plate (The lock is purchased separately). See Figure 4-8 for details:

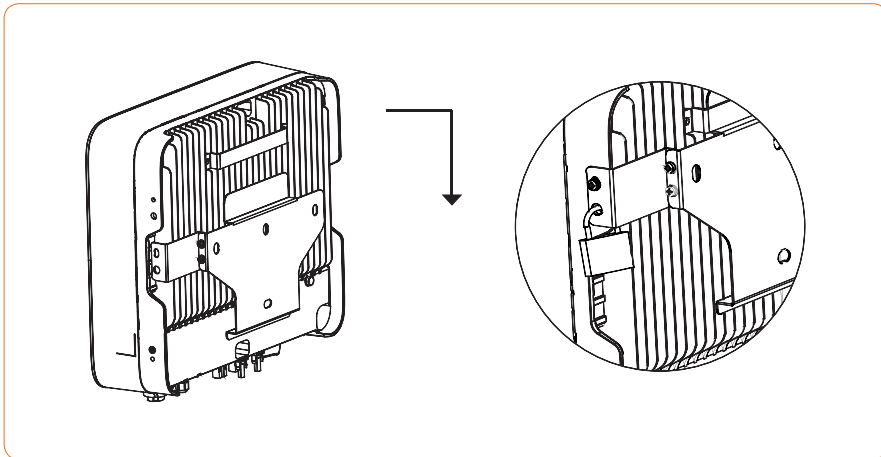



Figure 4-8 Mounting the inverter

※ 4.3 External ground connection

 Danger	Do not connect the N-wire as a protective ground wire to the inverter casing. Otherwise, it may cause electric shock.
 Attention	Good grounding is good for resisting surge voltage shock and improving EMI performance. Inverters must be well-grounded. For a system with only one inverter, the PE cable needs to be grounded. For a multi-inverter system, all inverters PE wires need to be connected to the same grounding copper bar to ensure equipotential bonding.

Ground terminal connection steps:

- ① The external grounding terminal is located in the lower right side of the inverter.
- ② Fix the grounding terminal to the PE wire with a proper tool and lock the grounding terminal to the grounding hole in the lower right side of the inverter, as shown in Figure 4-9.
- ③ The cross-sectional area of the external grounding cable is 4mm².

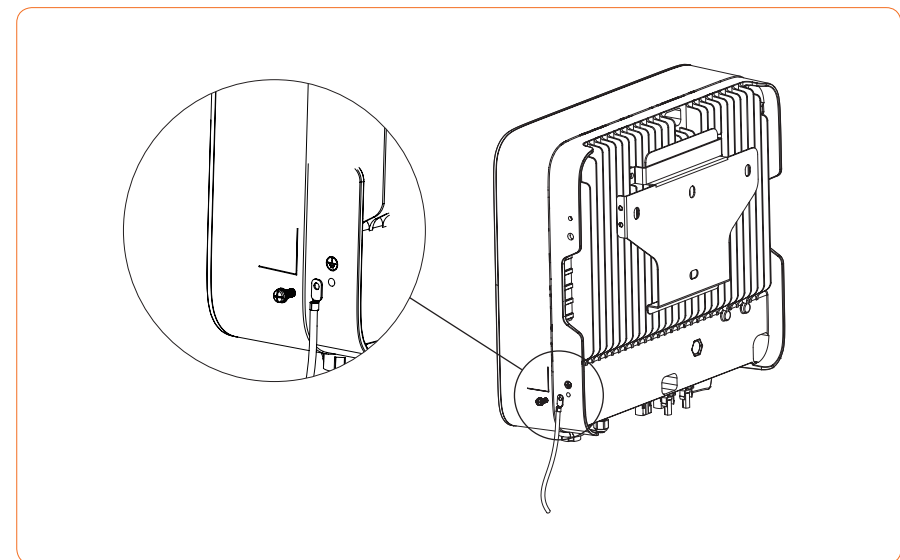







Figure 4-9 Grounding terminal connection

※ 4.4 Electrical Connection

 Danger	A high voltage in the conductive part of the inverter may cause an electric shock. When installing the inverter, make sure that the AC and DC sides of the inverter are completely de-energized.
 Warning	Do not ground the positive or negative pole of the PV string, otherwise it will cause serious damage to the inverter.
 Warning	Static may cause damage to the electronic components of the inverter. Anti- static measures should be taken during installation and maintenance.
 Attention	Do not use other brands or other types of terminals other than the terminals in the accessory package. Sunways has the right to refuse all damages caused by the mixed-use of terminals.
 Attention	Moisture and dust can damage the inverter, ensure the cable gland is securely tightened during installation. The warranty claim will be invalidated if the inverter is damaged as a result of a poorly connected cable connector.

▼ 4.4.1 Inverter PV string connection

1. The following must be considered when making electrical connections to the inverter:

- ① Disconnect the AC breaker switch on the grid side.
- ② The DC switch of the inverter must be turned to the "OFF" position.
- ③ For best practice, ensure PV modules of the same model and specifications are connected in each string.
- ④ Make sure the maximum output voltage of each PV string does not exceed 600V.

2. DC connector assembly procedure

① Select the appropriate photovoltaic cable:

Cable type	Traverse area (mm ²)	
General photovoltaic cable	Range (mm ²)	Recommended value (mm ²)
	2.5-4.0	4.0

② Peel off the DC cable insulation sleeve for 7 mm, as shown in Figure 4-10:

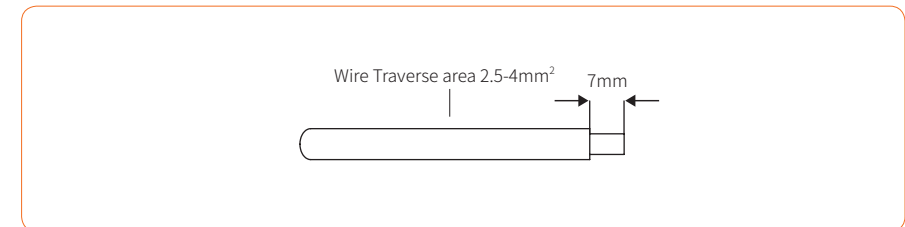

Figure 4-10

③ Disassemble the connector in the accessory bag, as shown in Figure 4-11:

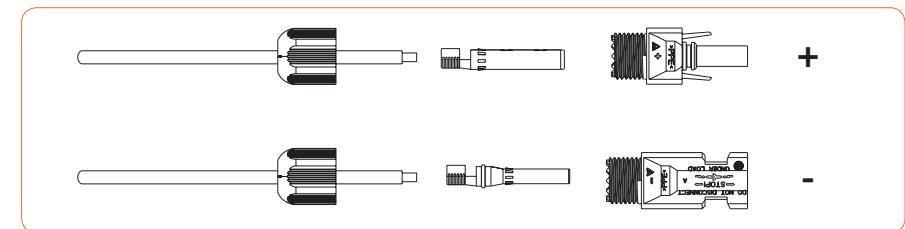

Figure 4-11

④ Insert the DC cable through the DC connector nut into the metal terminal and press the terminal with a professional crimping plier (pull back the cable with some power to check if the terminal is well connected to the cable), as shown in Figure 4-12:

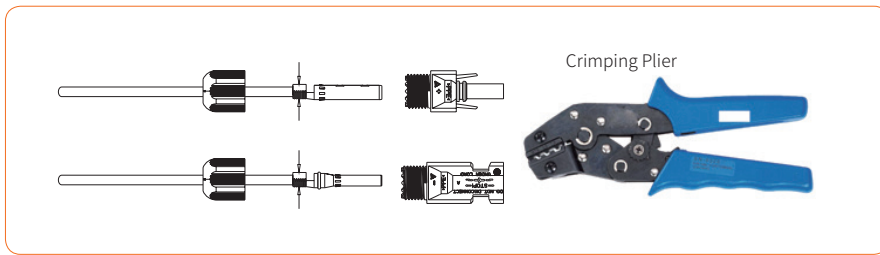

Figure 4-12

- ⑤ Insert the positive and negative cables into the corresponding positive and negative connectors, pull back the DC cable to ensure that the terminal is tightly attached in the connector.
- ⑥ Use an open-end wrench to screw the nut to the end to ensure that the terminal is well sealed, as shown in Figure 4-13:

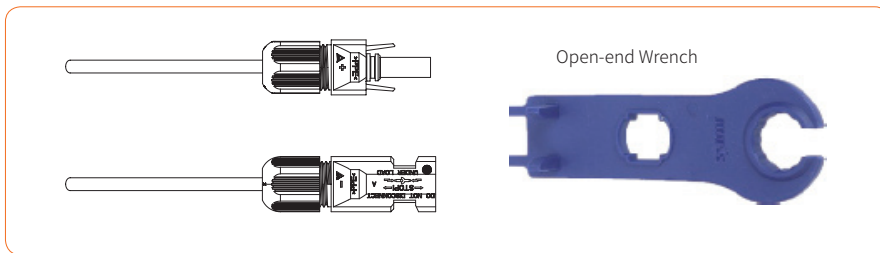

Figure 4-13



Warning

- ① Before assembling the DC connector, make sure that the cable polarity is correct.
- ② Use a multimeter to measure the voltage of the DC input string, verify the polarity of the DC input cable, and ensure that each string voltage is within 600V.

3. Insert the positive and negative connectors into the inverter DC input terminals respectively, a click sound should be heard if the terminals are well connected, as shown in Figure 4-14:

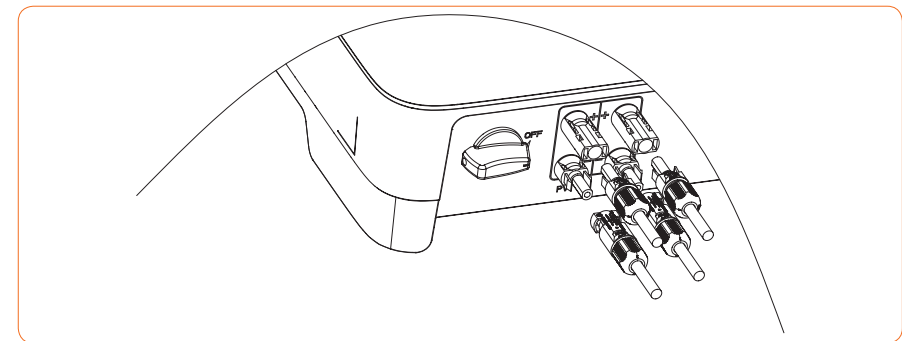

Figure 4-14

- 4. Seal the unused PV terminals with the terminal caps.
- 5. System Layout of Units without Integrated DC Switch

- ① The DC switch of Sunways inverter is optional. Local standards or codes may require that PV systems are fitted with an external DC switch on the DC side. The DC switch must be able to safely disconnect the open-circuit voltage of the PV array plus a safety reserve of 20%. Install a DC switch to each PV string to isolate the DC side of the inverter.
- ② The DC switch has to be certified by AS 60947.3:2018 and AS/NZS IEC 60947.1:2015. The Max.current of the DC switch matched by STS-3-6KTL inverter is no less than 30A and for STS-3-6KTL-P inverter is no less than 40A. We recommend the following electrical connection, as shown in Figure 4-15:

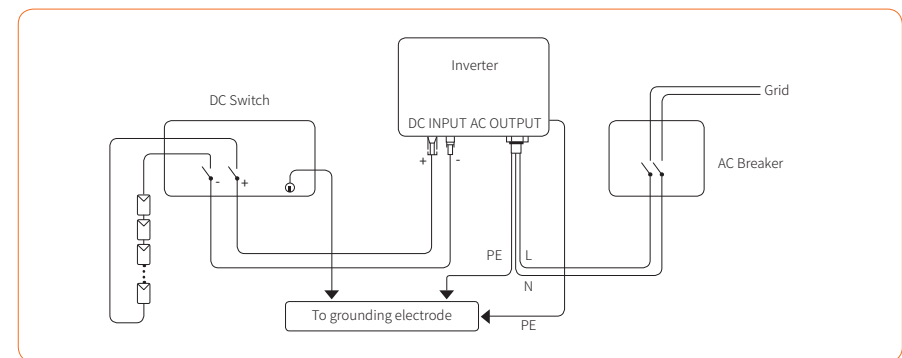

Figure 4-15

▼ 4.4.2 Connection of AC output

Before connecting to the power grid, make sure that the power grid voltage and frequency meet the requirements of the inverter. See technical parameters for details.

This inverter includes an integrated residual current device (RCD).

If an external residual current device (RCD) is used, a device of type (A/AC etc.) should be used, with a tripping current of 300mA or higher.

The recommended cable and AC switch for the Sunways STS 3-6kW series single phase inverter are shown in the following table:

Model	STS-3KTL	STS-3.6KTL	STS-4.2KTL	STS-4.6KTL	STS-5KTL	STS-6KTL
Cable	4mm ²	4 mm ²	4 mm ²	4 mm ²	6 mm ²	6 mm ²
Breaker	20A	25A	32A	32A	40A	40A



Warning

An AC breaker must be connected on the AC side of the inverter.
Any loads cannot be connected to the inverter without the AC breaker.

1. AC connector connection steps

① Take the AC connector out of the accessory bag and disassemble it, as shown in Figure 4-16:

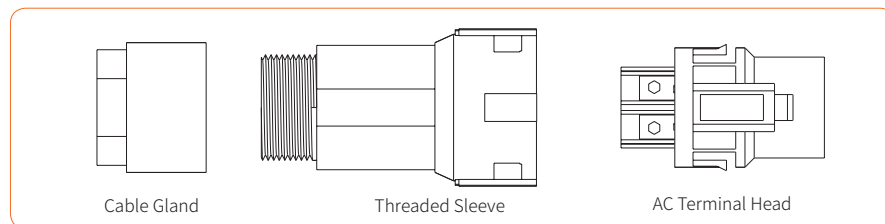

Figure 4-16

② According to the table above, select an appropriate cable, peel the insulation sleeve of AC cable off for 50mm, and peel off the end of L / PE / N wires for 8mm, as shown in Figure 4-17:

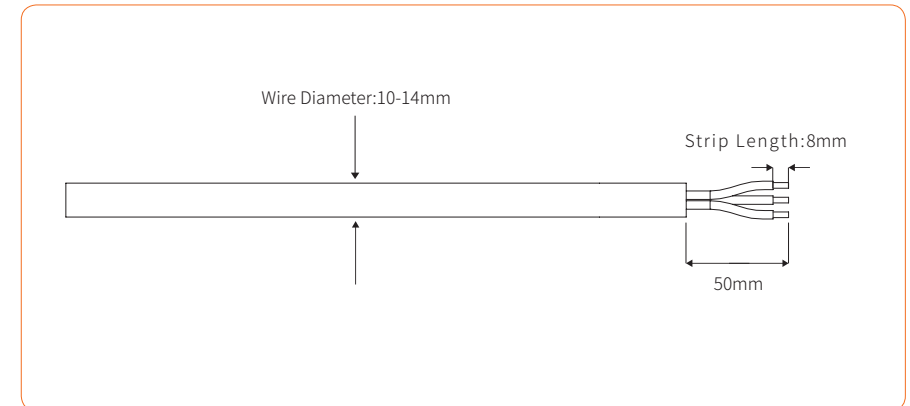

Figure 4-17

③ Insert the stripped end of each three wire into the appropriate hole of the terminal head (yellow green wire to PE port, red or brown wire to L port, and blue or black wire to the N port). Please try to pull out the cable to make sure it is well connected. As shown in Figure 4-18:

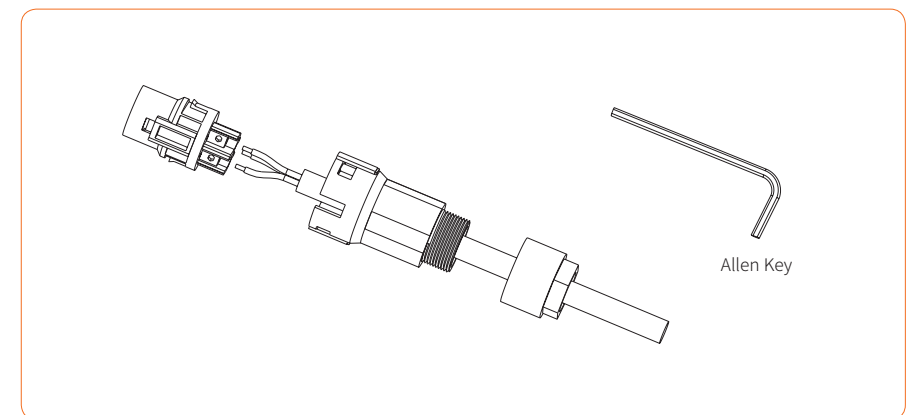

Figure 4-18

④ According to the arrow direction push the threaded sleeve to make it connected with the AC terminal head and then rotate the cable gland clockwise to lock it, as shown in figure 4-19:

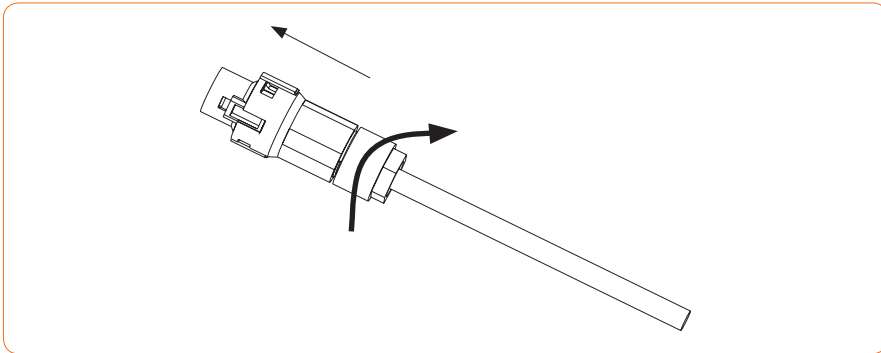

Figure 4-19

2. Connect the AC connector to the inverter AC terminal, and the slight click shows that the connection is in the place. As shown in figure 4-20:

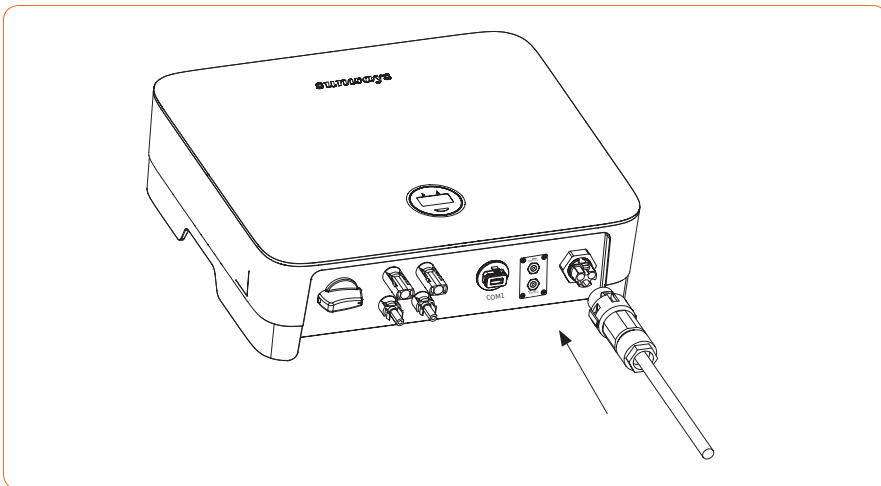

Figure 4-20 Connect the AC connector

※ 4.5 Monitoring Device Installation

Sunways STS 3-6kW series single phase inverter supports WIFI, GPRS, LAN, 4G and RS485 communication.

Plug the WIFI, LAN, 4G or GPRS module into the COM1 port in the bottom of inverter (as shown in Figure 4-21). A slight "click" sound during the installation represents that the assembly is in place.

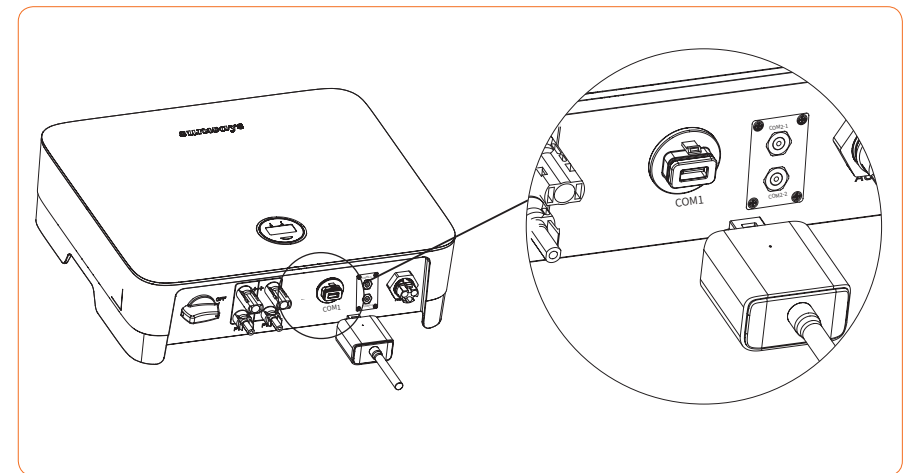

Figure 4-21 Monitoring device installation



Note

1. The 4G, and GPRS version module does not need to be configured.
2. The WiFi version module needs to be configured to the router for the first installation. If the router name or password are changed, the WiFi dongle will need to be reconfigured. For details, please refer to the [QUICK INSTALLATION GUIDE] which is attached to the accessory bag.
3. If DHCP is enabled on the router, the LAN version module does not need to be configured. Otherwise, please refer to the [QUICK INSTALLATION GUIDE] which is attached to the accessory bag.



Attention

Do not touch the waterproof plug in the card slot except for replacing the SIM card. In that case, please make sure the card slot is completely sealed by the waterproof plug after replacing the SIM card. Any damages caused by improper waterproof plug placement, will void warranty.

※ 4.6 CT/RS485/DRED Connection

▼ 4.6.1 Terminals definition

Inverter communication ports are located at the behind of the COM2 plate at the bottom and include CT port, RS485 port (used for Datalogger connection), and DRED port, as shown in Figure 4-22:

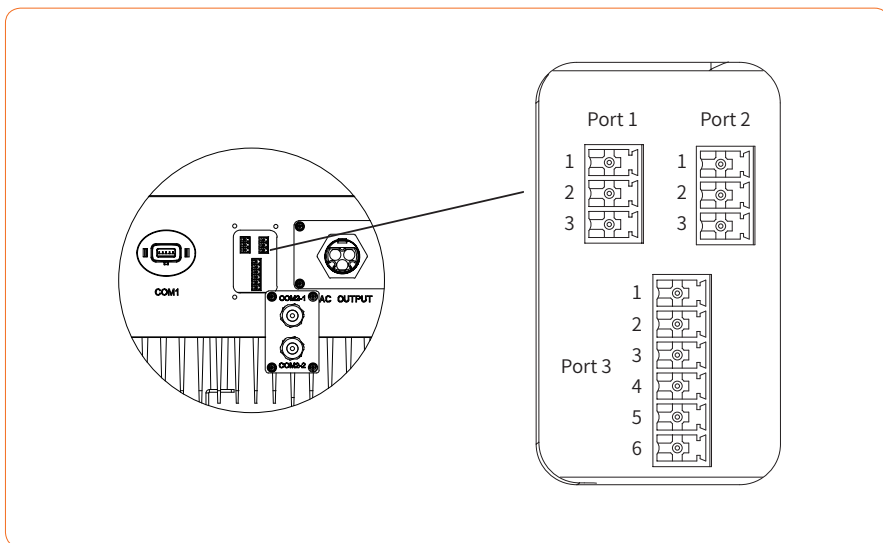

Figure 4-22

	Port 1	Port 2	Port3
	CT Port	RS485 Port	DRED Port
<p>Note</p>	① This port is available on export limitation & control, RS485 and DRED versions of the inverter only. ② The Pin connector in inverter Port1 and Port2 may vary from 2Pin to 3pin according to the shipment version.		

Different versions of the inverter have different terminals, which are defined as follows:

Port	Function	NO.	Definition
Port1	① Only Export limitation & control version with this port. ② Connect external CT to activate the Export Limitation & control function of Sunways STS series inverter. ③ The color of CT is only identified by Sunways.	1	Connect S1 cable (Black CT) or white black cable (Blue CT)
		2	Connect S2 cable (Black CT) or black cable (Blue CT)
		3	NULL
Port 2	① Export limitation & control/RS485/DRED version with this port. ② In case of multiple inverters, all the inverters can be daisy-chained via RS485 cables.	1	RS485 A
		2	RS485 B
		3	PE/NULL
Port 3	① Only DRED version with this port. ② DRED means demand response enable device. The AS/NZS 4777.2:2015 requires inverters to support demand response mode (DRM). This function is for inverters that comply with AS/NZS4777.2:2015 standard. ③ Sunways inverter is fully compliant with all DRM. The 6 pin connector is used for DRM connection. ④ Support DRM command: DRMO, DRM5, DRM6, DRM7, DRMB.	1	COM/DRMO
		2	REFGEN
		3	DRM4/8
		4	DRM3/7
		5	DRM2/6
		6	DRM1/5

▼ 4.6.2 RS485 Communication

STS series single-phase inverter supports multiple inverters daisy-chain connection to a data logger via RS485 communication.

Multiple inverters connection diagram as shown in Figure 4-23:

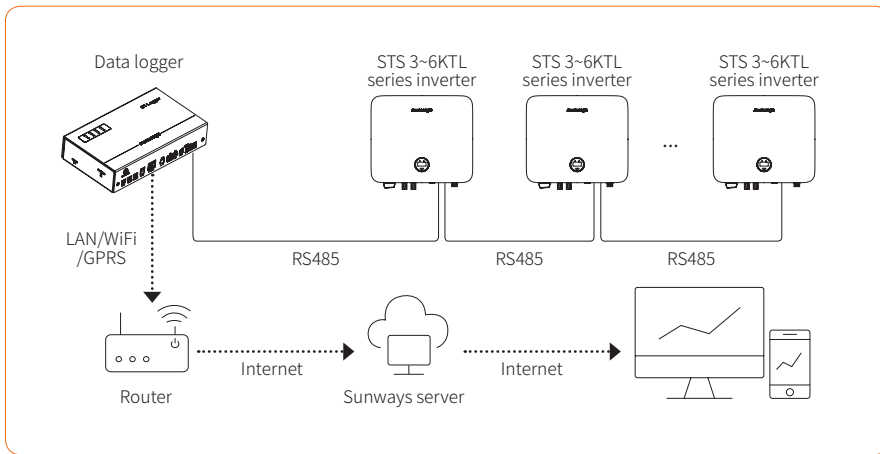

Figure 4-23

The maximum distance between the inverter at the end of the daisy chain and the Data logger should be within 1000m.



Attention

It is recommended to use the RS485 communication cable with a cross sectional area of 0.75-1.5mm² and an outer diameter of 5mm-10mm.
RS485 cable requirements: Shielded twisted-pair cable or shielded twisted Ethernet cable.

▼ 4.6.3 Export limitation & control or power limit solution

Export limitation & control or power limit solution, wiring instructions and configuration, please contact Sunways after-sales at service@sunways-tech.com.

▼ 4.6.4 Wiring Steps:

- ① Remove the COM2 plate in the bottom of the inverter with a cross screwdriver.
- ② Put the cable through the connector and connect to the terminal in the following order: screw cap, sealing ring, insulator, metal plate, nut and 3/6pin connector, as shown in Figure 4-24:

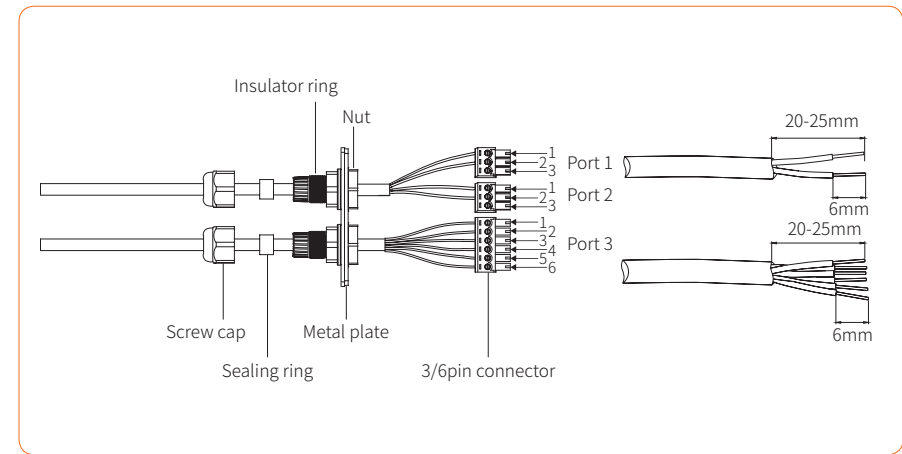

Figure 4-24

- ③ Insert the cable to the port in the 3/6pin connector and fasten with a screwdriver.
- ④ Insert the 3/6pin connector into the 3/6pin connector inside the inverter, and screw the COM2 plate back with a cross screwdriver, as shown in Figure 4-25:

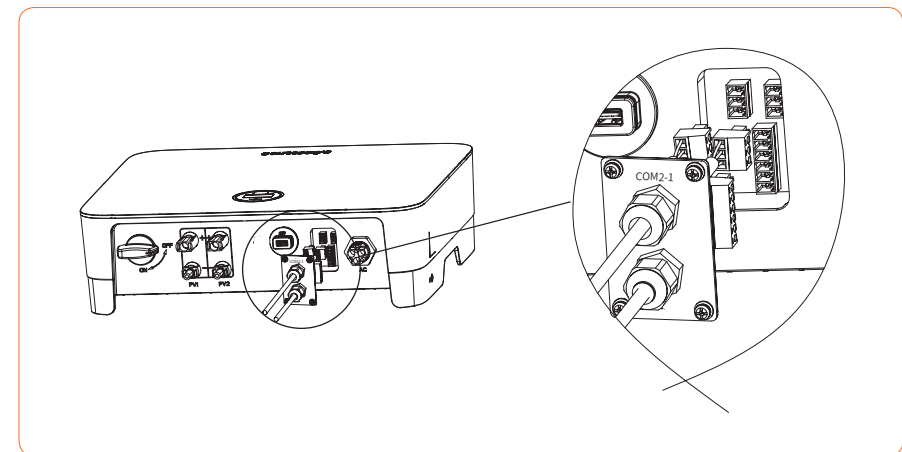

Figure 4-25

» 5 Start and Stop

※ 5.1 Start the Inverter

When starting the inverter, follow these steps:

- ① Turn on the AC breaker first (close the AC circuit breaker).
- ② Turn on the DC switch in the bottom. If the PV string voltage higher than the inverter start-up voltage, the inverter will start.
- ③ When both AC and DC power supply are normal, the inverter is ready to start. The inverter will initiate checking its internal parameters and grid parameters, if it is within the range, the green light on the left side of the screen begins to flash, and the “Waiting” message will be displayed on the OLED display.
- ④ After self-checking completed, the inverter will start generating electricity, the green light will remain on, and the OLED display will display real-time power information.

※ 5.2 Stop the Inverter

When turning off the inverter, please follow the steps below:

- ① Turn off the AC breaker first.
- ② Wait 30 seconds and then turn the DC switch to the “OFF” position. At this time, there is remaining power in the inverter capacitor. Wait for 5 minutes until the inverter is completely de-energized before conducting any work on the inverter.
- ③ Disconnect the AC and DC cables.

» 6 General Operation

※ 6.1 Display Operation

When the inverter is turned on, the following interfaces will be displayed on the OLED display, and the OLED display allows the user to check various operation information and to modify the settings of the inverter. Please refer to the following display operation flow for details:

▼ 6.1.1 Main Window and General Setting

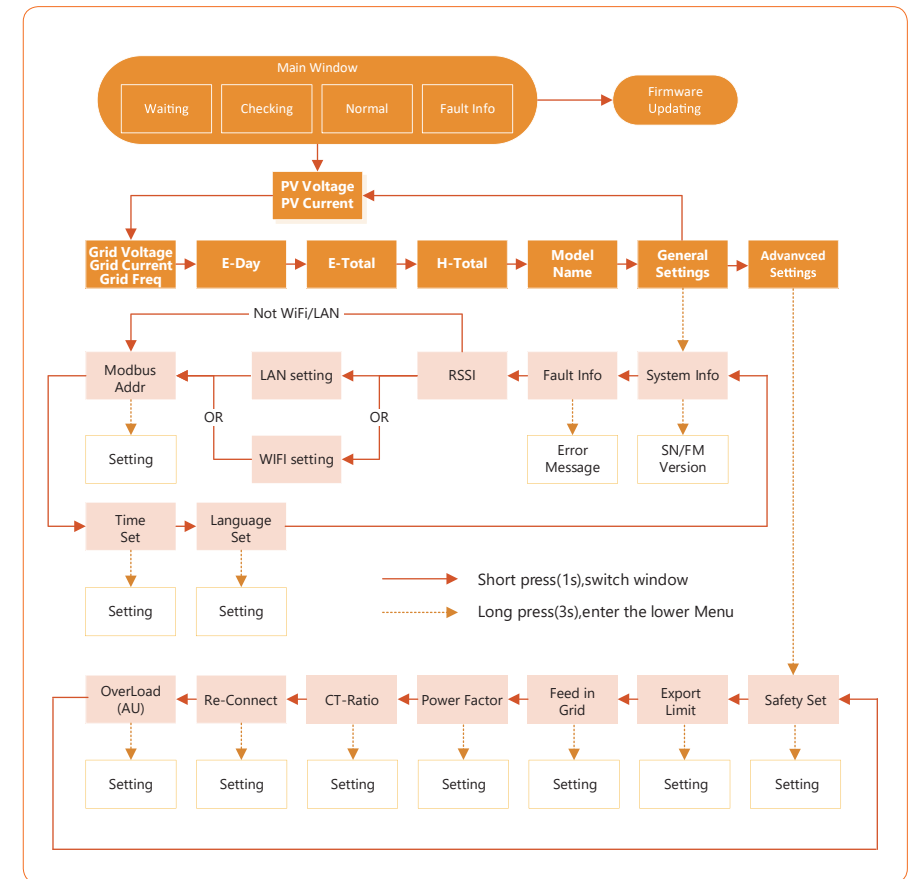

▼ 6.1.2 LAN/WIFI Setting

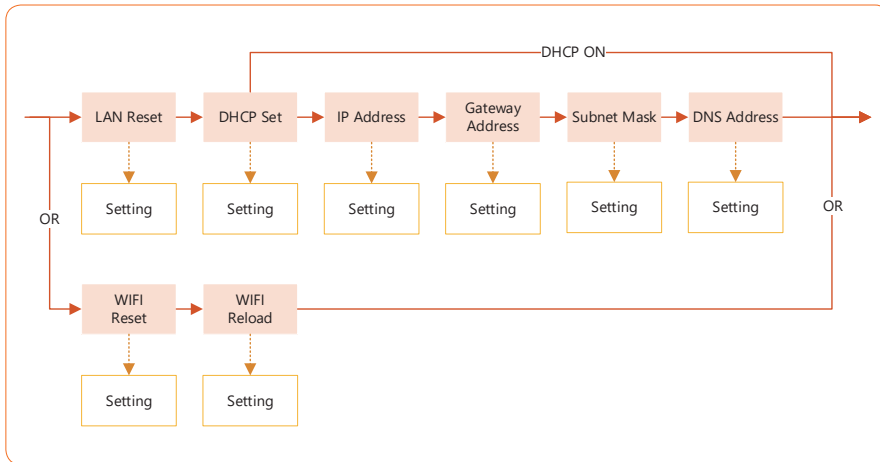

Note

Please wait for 10 seconds and the inverter will automatically save your settings or modifications.

※ 6.2 Country Code (Safety Code) Setting

Please set "Country code (Safety code)" under the menu "Safety Set" in "Advanced Settings".

Please follow this flow chart to set "Country code (Safety code)":

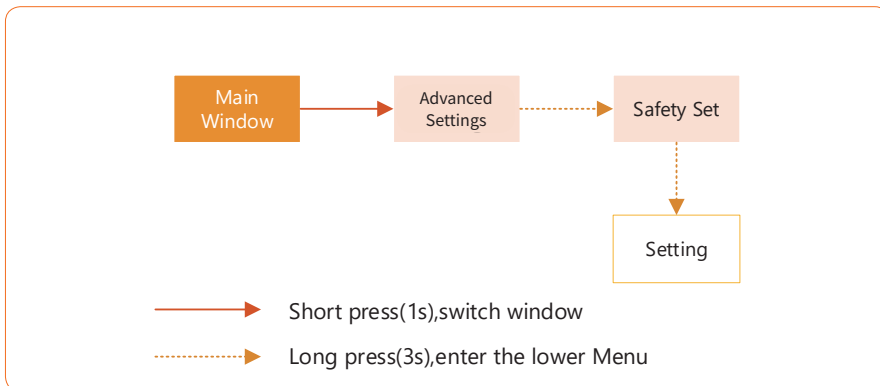

※ 6.3 AC Output Boost for STS-5KTL Inverter

The maximum output power of the residential single-phase solar system is 5kVA in most of the states in Australia. Check the local DNSPs or authorities if they allow AC output more than 5kVA.



Note

- ① Advanced settings can only be changed by qualified professionals with relevant certifications.
- ② Check requirements with local NSP before activating 10% AC output boost.
- ③ Only STS-5KTL has the option to enable/disable the 10% AC output boost.
- ④ The default password to access the advanced settings is 1111, applicable to all on-grid inverters.

Please follow this flow chart to enable 10% AC output boost:

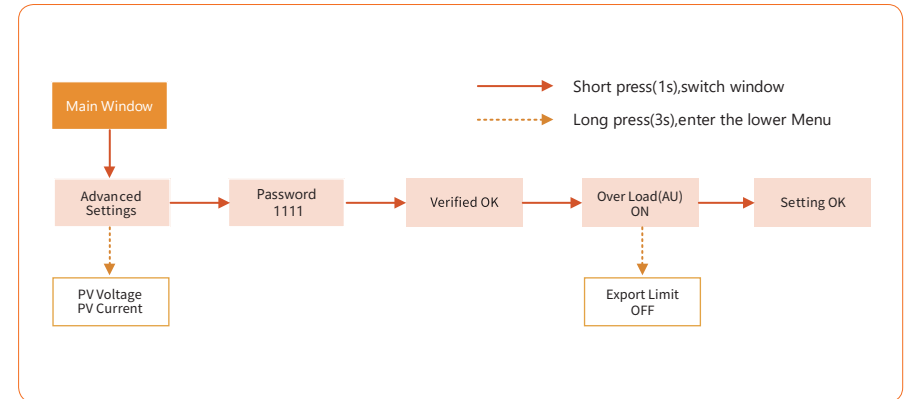

※ 6.4 Power Quality Response Modes

▼ 6.4.1 Power derating for voltage variation (Volt-Watt mode)

This mode can be enabled via the configuration software. Please contact Sunways Technical Support at service@sunways-tech.com for more information.

▼ 6.4.2 Reactive power regulation for voltage variation (Volt-VAR mode)

This mode can be enabled via the configuration software. Please contact Sunways Technical Support at service@sunways-tech.com for more information.

※ 6.5 Online Monitoring APP

Sunways inverter provides a monitoring port that can collect and transmit data from the inverter to Sunways monitoring platform via an external monitoring device. Please refer to the product nameplate on side of enclosure to get the monitoring application. If download issues exist, contact your dealer or Sunways technical support.

» 7 Troubleshooting

※ 7.1 Error Message

Sunways STS 3-6kW series single phase inverter is designed in accordance with grid operation standards, and conform to the requirements of safety and EMC. The inverter had passed a series of rigorous tests to ensure it runs sustainably and reliably before shipment.





When a fault occurs, the corresponding error message will be shown on the OLED display, and in this case, the inverter might stop feeding into grid. The fault messages and their corresponding troubleshooting methods are listed below:

Error Message	Description	Troubleshooting
No Display	No Display	① Check whether cables are all firmly connected and DC switch is on. ② Check whether the input voltage meets the working voltage.
Mains Lost	Grid power outage, AC switch or circuit is disconnected.	① Check whether the mains supply is lost. ② Check whether the AC breaker and terminals are well connected.
Grid Voltage Fault	Grid overvoltage or undervoltage, the grid voltage is higher or lower than the set protection value.	① Check whether the safety regulation setting is correct. ② Check the voltage of the grid. If the grid voltage exceeds the allowed range of inverter protection parameters, please contact the local grid company to resolve. ③ Check whether the impedance of the AC cable is too high. Replace with a thicker AC cable if that is the case.
Grid Frequency Fault	Grid over frequency or under-frequency, the grid frequency is higher or lower than the set protection value.	① Check whether the safety regulation settings are correct. ② Check the frequency of the grid. If the grid frequency exceeds the allowed range of inverter protection parameters, please contact the local grid company to resolve.

Error Message	Description	Troubleshooting
ISO Over Limitation	Low system insulation resistance, which is generally caused by poor insulation to ground of the module/cable or by rainy and damp environment.	<ol style="list-style-type: none"> ① Check whether the PV panels, cables, and connectors are broken or water leaked. ② Check whether there is a reliable inverter grounding line.
GFCI Fault	Excessive leakage current.	<ol style="list-style-type: none"> ① The ground current is too high. ② Check whether the PV cable has a short circuit to ground.
PV Over Voltage	PV over voltage is too high.	<ol style="list-style-type: none"> ① Input voltage is too high. ② Reduce the number of PV panels to make sure the open-circuit voltage of each string is lower than the inverter max allowed input voltage.
Inverter Over Temperature	Temperature anomaly, the temperature of the interior of the inverter is excessively high and out of the safe range.	<ol style="list-style-type: none"> ① Check whether the inverter is directly exposed to the sunlight. ② Reduce ambient temperature.
DCI Fault	DC Injection Hight. Inverter detects a higher DC component in AC output.	<ol style="list-style-type: none"> ① Restart the inverter, wait a moment for inverter recovery. ② If the fault occurs repeatedly, please contact Sunways.
Bus Voltage Fault	BUS voltage is over-high.	<ol style="list-style-type: none"> ① Restart the inverter, wait a moment for inverter recovery. ② If the fault occurs repeatedly, please contact Sunways.
SCI Fault	Internal communication fails. Caused by a strong external magnetic field etc.	<ol style="list-style-type: none"> ① Restart the inverter, wait a moment for inverter recovery. ② If the fault occurs repeatedly, please contact Sunways.
SPI Fault	Internal communication fails. Caused by a strong external magnetic field etc.	<ol style="list-style-type: none"> ① Restart the inverter, wait a moment for inverter recovery. ② If the fault occurs repeatedly, please contact Sunways.

Error Message	Description	Troubleshooting
E2 Fault	Internal storage anomaly. Caused by a strong external magnetic field etc.	<ol style="list-style-type: none"> ① Restart the inverter, wait a moment for inverter recovery. ② If the fault occurs repeatedly, please contact Sunways.
GFCI Device Fault	GFCI device anomaly.	<ol style="list-style-type: none"> ① Restart the inverter, wait a moment for inverter recovery. ② If the fault occurs repeatedly, please contact Sunways.
AC Transducer Fault	AC transducer anomaly.	<ol style="list-style-type: none"> ① Restart the inverter, wait a moment for inverter recovery. ② If the fault occurs repeatedly, please contact Sunways.
Relay Check Fail	Self-checking of relay fails. neutral & ground cable are not connected well on AC side or just occasional failure.	<ol style="list-style-type: none"> ① Check use multi-meter if there is high voltage (normally should be lower than 10V) between N&PE cable on AC side. If the voltage higher than 10V, it means the Neutral & ground cable are not connected well on AC side or restart inverter. ② If the neutral & ground cable are connected well, please contact Sunways.
Flash Fault	Internal storage anomaly. Caused by a strong external magnetic field etc.	<ol style="list-style-type: none"> ① Restart the inverter, wait a moment for inverter recovery. ② If the fault occurs repeatedly, please contact Sunways.
External Fan Fault	External fan anomaly.	<ol style="list-style-type: none"> ① Stop the inverter and disconnect the AC&DC cables. ② Check whether the fan is blocked by foreign matters. If not, replace the fan.
Internal Fan Fault	Internal fan anomaly.	<ol style="list-style-type: none"> ① Restart the inverter, wait a moment for inverter recovery. ② If the fault occurs repeatedly, please contact Sunways.

※ 7.2 Maintenance

 Danger	<p>Risk of inverter damage or personal injury due to incorrect service! Always keep in mind that the inverter is powered by dual sources: PV strings and utility grid. Before any service work, observe the following procedure.</p> <p>① Disconnect the AC circuit breaker and then set the DC load-break switch of the inverter to OFF; ② Wait at least 5 minutes for inner capacitors to discharge completely; ③ Verify that there is no voltage or current before pulling any connector.</p>
 Caution	<p>Keep non-qualified persons away! A temporary warning sign or barrier must be posted to keep non-qualified persons away while performing electrical connection and service work.</p>
 Attention	<p>Restart the inverter only after removing the fault that impairs safety performance. Never arbitrarily replace any internal components. For any maintenance support, please contact Sunways. Otherwise, Sunways shall not be held liable for any damage caused.</p>
 Note	<p>Servicing of the device in accordance with the manual should never be undertaken in the absence of proper tools, test equipment or the latest revision of the manual which has been clearly and thoroughly understood.</p>

Items	Methods	Period
System clean	Check the temperature and dust of the inverter. Clean the inverter enclosure if necessary. Check if the air inlet and outlet are normal. Clean the air inlet and outlet if necessary.	Six months to a year (it depends on the dust contents in air.)

» 8 Technical Parameters

Model	STS-3KTL	STS-3KTL-P	STS-3.6KTL	STS-3.6KTL-P
Input				
Start-up Voltage (V)	120	80	120	80
Max. DC Input Voltage (V)	600	600	600	600
Rated DC Input Voltage (V)	360	360	360	360
MPPT Voltage Range (V)	100-550	100-550	100-550	100-550
No. of MPP Trackers	2	2	2	2
No. of DC Inputs per MPPT	1/1	1/1	1/1	1/1
Max. Input Current (A)	12.5/12.5	15/15	12.5/12.5	15/15
Max. Short-circuit Current (A)	15	20/20	15	20/20
Back feed current to the array (A)	0	0	0	0
Output				
Rated Output Power (W)	3,000	3,000	3,600	3,600
Max. Output Power (W)	3,300	3,300	3,960 ^①	3,960 ^①
AC output rated apparent power (VA)	3,000	3,000	3,600	3,600
Max. Apparent Power (VA)	3,300	3,300	3,960 ^①	3,960 ^①
Rated Output Voltage (V)	220/230	220/230	220/230	220/230
Rated AC Frequency (Hz)	50/60	50/60	50/60	50/60
AC output rated current (A)	13	13	15.7	15.7
Max. Output Current (A)	15	15	18 ^②	18 ^②
The measured Inrush current (A)	13.5A@44μs	13.5A@44μs	13.5A@44μs	13.5A@44μs
Maximum output fault current (A)	50	50	50	50
Maximum output overcurrent protection (A)	50	50	50	50
Power Factor	0.8 leading ... 0.8 lagging			
Max. total harmonic distortion	<3% @Rated Output Power			
DCI	<0.5%In	<0.5%In	<0.5%In	<0.5%In
Efficiency				
Max. Efficiency	98.1%	98.1%	98.1%	98.1%
European Efficiency	97.5%	97.5%	97.5%	97.5%

Model	STS-3KTL	STS-3KTL-P	STS-3.6KTL	STS-3.6KTL-P
MPPT Efficiency	99.9%	99.9%	99.9%	99.9%
Protection				
DC Reverse Polarity Protection	Integrated			
Insulation Resistance Protection	Integrated			
DC Switch	Optional			
Surge Protection	Integrated			
Over-temperature Protection	Integrated			
Residual Current Protection	Integrated			
Islanding protection	Frequency shift, Integrated			
AC Short-circuit Protection	Integrated			
AC Over-voltage Protection	Integrated			
General Data				
Dimensions (mm)	410W*360H*120D			
Weight (KG)	13	13	13	13
Protection Degree	IP65	IP65	IP65	IP65
Self-consumption at Night (W)	<1	<1	<1	<1
Topology	Transformer less			
Operating Temperature Range (° C)	-30~60	-30~60	-30~60	-30~60
Relative Humidity	0~100%	0~100%	0~100%	0~100%
Operating Altitude (m)	3000	3000	3000	3000
Cooling	Natural Convection			
Noise Level (dB)	<25	<25	<25	<25
Display	OLED & LED			
Communication	RS485/WiFi/GPRS/LAN/4G (Optional)			
Compliance	NB/T 32004、IEC62109、IEC62116、VDE 4105、VDE 0126、UTE C15-712-1、AS4777、C10/11、CEI 0-21、RD1699、NBR16149、IEC61727、IEC60068、IEC61683、EN50549、EN61000			

① 3680W for the regulation of G98/G99 ② 16A for the regulation of G98/G99

Model	STS-4.2KTL	STS-4.2KTL-P	STS-4.6KTL	STS-4.6KTL-P
Input				
Start-up Voltage (V)	120	80	120	80
Max. DC Input Voltage (V)	600	600	600	600
Rated DC Input Voltage (V)	360	360	360	360
MPPT Voltage Range (V)	100~550	100~550	100~550	100~550
No. of MPP Trackers	2	2	2	2
No. of DC Inputs per MPPT	1/1	1/1	1/1	1/1
Max. Input Current (A)	12.5/12.5	15/15	12.5/12.5	15/15
Max. Short-circuit Current (A)	15	20/20	15	20/20
Back feed current to the array (A)	0	0	0	0
Output				
Rated Output Power (W)	4,200	4,200	4,600	4,600
Max. Output Power (W)	4,600	4,600	4,600	4,600
AC output rated apparent power (VA)	4,200	4,200	4,600	4,600
Max. Apparent Power (VA)	4,600	4,600	4,600	4,600
Rated Output Voltage (V)	220/230	220/230	220/230	220/230
Rated AC Frequency (Hz)	50/60	50/60	50/60	50/60
AC output rated current (A)	18.3	18.3	20	20
Max. Output Current (A)	21	21	21	21
The measured Inrush current (A)	31.5A@55μs	31.5A@55μs	31.5A@55μs	31.5A@55μs
Maximum output fault current (A)	50	50	50	50
Maximum output overcurrent protection (A)	50	50	50	50
Power Factor	0.8 leading ... 0.8 lagging			
Max. total harmonic distortion	<3% @Rated Output Power			
DCI	<0.5%In	<0.5%In	<0.5%In	<0.5%In
Efficiency				
Max. Efficiency	98.1%	98.1%	98.1%	98.1%
European Efficiency	97.5%	97.5%	97.5%	97.5%
MPPT Efficiency	99.9%	99.9%	99.9%	99.9%

Model	STS-4.2KTL	STS-4.2KTL-P	STS-4.6KTL	STS-4.6KTL-P
Protection				
DC Reverse Polarity Protection	Integrated			
Insulation Resistance Protection	Integrated			
DC Switch	Optional			
Surge Protection	Integrated			
Over-temperature Protection	Integrated			
Residual Current Protection	Integrated			
Islanding protection	Frequency shift, Integrated			
AC Short-circuit Protection	Integrated			
AC Over-voltage Protection	Integrated			
General Data				
Dimensions (mm)	410W*360H*120D			
Weight (KG)	13	13	13	13
Protection Degree	IP65	IP65	IP65	IP65
Self-consumption at Night (W)	<1	<1	<1	<1
Topology	Transformer less			
Operating Temperature Range (° C)	-30~60	-30~60	-30~60	-30~60
Relative Humidity	0~100%	0~100%	0~100%	0~100%
Operating Altitude (m)	3000	3000	3000	3000
Cooling	Natural Convection			
Noise Level (dB)	<25	<25	<25	<25
Display	OLED & LED			
Communication	RS485/WiFi/GPRS/LAN/4G (Optional)			
Compliance	NB/T 32004、IEC62109、IEC62116、VDE 4105、VDE 0126、UTE C15-712-1、AS4777、C10/11、CEI0-21、RD1699、NBR16149、IEC61727、IEC60068、IEC61683、EN50549、EN61000			

Model	STS-5KTL	STS-5KTL-P	STS-6KTL	STS-6KTL-P
Input				
Start-up Voltage (V)	120	80	120	80
Max. DC Input Voltage (V)	600	600	600	600
Rated DC Input Voltage (V)	360	360	360	360
MPPT Voltage Range (V)	100~550	100~550	100~550	100~550
No. of MPP Trackers	2	2	2	2
No. of DC Inputs per MPPT	1/1	1/1	1/1	1/1
Max. Input Current (A)	12.5/12.5	15/15	12.5/12.5	15/15
Max. Short-circuit Current (A)	15	20/20	15	20/20
Back feed current to the array (A)	0	0	0	0
Output				
Rated Output Power (W)	5,000	5,000	6,000	6,000
Max. Output Power (W)	5,500 ^③	5,500 ^③	6,600	6,600
AC output rated apparent power (VA)	5,000	5,000	6,000	6,000
Max. Apparent Power (VA)	5,500	5,500	6,600	6,600
Rated Output Voltage (V)	220/230	220/230	220/230	220/230
Rated AC Frequency (Hz)	50/60	50/60	50/60	50/60
AC output rated current (A)	21.7	21.7	26.1	26.1
Max. Output Current (A)	25 ^④	25 ^④	28.7	28.7
The measured Inrush current (A)	31.5A@55μs	31.5A@55μs	31.5A@55μs	31.5A@55μs
Maximum output fault current (A)	50	50	50	50
Maximum output overcurrent protection (A)	50	50	50	50
Power Factor	0.8 leading ... 0.8 lagging			
Max. total harmonic distortion	<3% @Rated Output Power			
DCI	<0.5%In	<0.5%In	<0.5%In	<0.5%In
Efficiency				
Max. Efficiency	98.1%	98.1%	98.1%	98.1%
European Efficiency	97.5%	97.5%	97.5%	97.5%
MPPT Efficiency	99.9%	99.9%	99.9%	99.9%

Model	STS-5KTL	STS-5KTL-P	STS-6KTL	STS-6KTL-P
Protection				
DC Reverse Polarity Protection	Integrated			
Insulation Resistance Protection	Integrated			
DC Switch	Optional			
Surge Protection	Integrated			
Over-temperature Protection	Integrated			
Residual Current Protection	Integrated			
Islanding protection	Frequency shift, Integrated			
AC Short-circuit Protection	Integrated			
AC Over-voltage Protection	Integrated			
General Data				
Dimensions (mm)	410W*360H*120D			
Weight (KG)	13	13	13	13
Protection Degree	IP65	IP65	IP65	IP65
Self-consumption at Night (W)	<1	<1	<1	<1
Topology	Transformer less			
Operating Temperature Range (° C)	-30~60	-30~60	-30~60	-30~60
Relative Humidity	0~100%	0~100%	0~100%	0~100%
Operating Altitude (m)	3000	3000	3000	3000
Cooling	Natural Convection			
Noise Level (dB)	<25	<25	<25	<25
Display	OLED & LED			
Communication	RS485/WiFi/GPRS/LAN/4G (Optional)			
Compliance	NB/T 32004、IEC62109、IEC62116、VDE 4105、VDE 0126、UTE C15-712-1、AS4777、C10/11、CEI0-21、RD1699、NBR16149、IEC61727、IEC60068、IEC61683、EN50549、EN61000			

③ 5000W for the regulation of C10/11

④ 21.7A for the regulation of C10/11

sunways

📍 No. 1, Second Road, Green Industrial Zone, Chongshou Town,
Cixi City, ZheJiang Province, PRC

🌐 www.sunways-tech.com

✉ service@sunways-tech.com